



W-300 and W-400 WELDING TORCH with CW-300 and CW-400 CUTTING ATTACHMENTS



Instruction Manual

**BE SURE THIS INFORMATION REACHES THE OPERATOR.
YOU CAN GET EXTRA COPIES THROUGH YOUR SUPPLIER.**

 **CAUTION**

These INSTRUCTIONS are for experienced operators. If you are not fully familiar with the principles of operation and safe practices for arc welding and cutting equipment, we urge you to read our booklet, "Precautions and Safe Practices for Arc Welding, Cutting, and Gouging," Form 52-529. Do NOT permit untrained persons to install, operate, or maintain this equipment. Do NOT attempt to install or operate this equipment until you have read and fully understand these instructions. If you do not fully understand these instructions, contact your supplier for further information. Be sure to read the Safety Precautions before installing or operating this equipment.

USER RESPONSIBILITY

This equipment will perform in conformity with the description thereof contained in this manual and accompanying labels and/or inserts when installed, operated, maintained and repaired in accordance with the instructions provided. This equipment must be checked periodically. Malfunctioning or poorly maintained equipment should not be used. Parts that are broken, missing, worn, distorted or contaminated should be replaced immediately. Should such repair or replacement become necessary, the manufacturer recommends that a telephone or written request for service advice be made to the Authorized Distributor from whom it was purchased.

This equipment or any of its parts should not be altered without the prior written approval of the manufacturer. The user of this equipment shall have the sole responsibility for any malfunction which results from improper use, faulty maintenance, damage, improper repair or alteration by anyone other than the manufacturer or a service facility designated by the manufacturer.

TABLE OF CONTENTS

SECTION	TITLE	PAGE
SECTION 1	SAFETY	5
SECTION 2	DESCRIPTION.....	7
SECTION 3	OPERATION	9
SECTION 4	MAINTENANCE	15
SECTION 5	REPLACEMENT PARTS.....	17

TABLE OF CONTENTS

WARNING

These Safety Precautions are for your protection. They summarize precautionary information from the references listed in Additional Safety Information section. Before performing any installation or operating procedures, be sure to read and follow the safety precautions listed below as well as all other manuals, material safety data sheets, labels, etc. Failure to observe Safety Precautions can result in injury or death.



PROTECT YOURSELF AND OTHERS - Some welding, cutting and gouging processes are noisy and require ear protection. Hot metal can cause skin burns and heat rays may injure eyes. Training in the proper use of the processes and equipment is essential to prevent accidents. Also:

1. Always wear safety glasses with side shields in any work area, even if welding helmets, face shields, or goggles are also required.
2. Wear flameproof gauntlet type gloves, heavy long-sleeve shirt, cuffless trousers, high-topped shoes, and a welding helmet or cap for hair protection, to protect against hot sparks and hot metal. A flameproof apron may also be desirable as protection against radiated heat and sparks.
3. Hot sparks or metal can lodge in rolled up sleeves, trousers cuffs, or pockets. Sleeves and collars should be kept buttoned, and open pockets eliminated from the front of clothing.
4. Protect other personnel from hot sparks with a suitable non-flammable partition or curtains.
5. Use goggles over safety glasses when chipping slag or grinding. Chipped slag may be hot and can travel considerable distances. Bystanders should also wear goggles over safety glasses.



FIRES AND EXPLOSIONS - Heat from a flame can act as an ignition source. Hot slag or sparks can also cause fires or explosions. Therefore:

1. Remove all combustible materials well away from the work area or completely cover the materials with a protective non-flammable covering. Combustible materials include wood, cloth, sawdust, liquid and gas fuels, solvents, paints and coatings, paper, etc.
2. Hot sparks or hot metal can fall through cracks or crevices in floors or wall openings and cause a hidden smoldering fire on the floor below. Make certain that such openings are protected from hot sparks and metal.
3. Do not weld, cut, or perform any other hot work on materials, containers, or piping until it has been completely cleaned so that no substances on the material can produce flammable or toxic vapors. Do not do hot work on closed containers. They may explode.
4. Have fire extinguishing equipment handy for instant use, such as a garden hose, a pail of water or sand, or portable fire extinguisher. Be sure you are trained in its use.
5. After completing operations, inspect the work area to be sure that there are no hot sparks or hot metal which could cause a later fire. Use fire watchers when necessary.
6. For additional information, refer to NFPA Standard 51B, "Fire Prevention in Use of Cutting and Welding Processes", which is available from the National Fire Protection Association, Batterymarch Park, Quincy, MA 02269.



FUMES AND GASES - Fumes and gases, particularly in confined spaces, can cause discomfort or injury. Do not breathe fumes or gases from welding or cutting, Therefore:

1. Always provide adequate ventilation in the work area by natural or mechanical ventilation means. Do not weld, cut, or gouge on materials such as galvanized steel, stainless steel, copper, zinc, lead, beryllium, or cadmium unless positive mechanical ventilation is provided. Do not breathe fumes and gases from these materials.
2. If you develop momentary eye, nose, or throat irritation while operating, this is an indication that ventilation is not adequate. Stop work at once and take necessary steps to improve ventilation in the work area. Do not continue to operate if physical discomfort persists.
3. Refer to ANSI/ASC Standard Z49.1 listed below for specific ventilation recommendations.

EQUIPMENT MAINTENANCE - Faulty or improperly maintained equipment, such as torches, hoses and regulators, can result in poor work, but even more important, it can cause injury or death through fires. Therefore:



1. Always have qualified personnel perform the installation, troubleshooting, and maintenance work. Do not operate or repair any equipment unless you are qualified to do so.
2. Keep all oxy-fuel equipment free of grease or oil. Grease, oil, and other similar combustible materials, when ignited, can burn violently in the presence of oxygen.
3. Do not abuse any equipment or accessories. Keep equipment away from heat and wet conditions, oil or grease, corrosive atmospheres and inclement weather.
4. Keep all safety devices in position and in good repair.
5. Use equipment for its intended purpose. Do not modify it in any manner.

GAS CYLINDER HANDLING - Gas cylinders, if mishandled, can rupture or explode violently. Sudden rupture of a cylinder, valve or relief device can injure or kill you. Therefore:



1. Use the proper gas for the process and use the proper pressure reducing regulator designed to operate from the compressed gas cylinder. Do not use adaptors to mount the regulator on the cylinder. Maintain hoses and fittings in good condition. Follow manufacturer's operating instructions for mounting the regulator to the gas cylinder.
2. Always secure cylinders in an upright position by chain or strap to suitable hand trucks, benches, walls, post, or racks. Never secure cylinders to work tables or fixtures where they may become part of an electrical circuit.
3. When not in use, keep cylinder valves closed. Have the valve protection cap in place on top of the cylinder if no regulators is installed. Secure and move cylinders by using suitable hand trucks. Avoid rough handling of cylinders.
4. Locate cylinders away from heat, sparks, or flame of a welding, cutting, or gouging operation. Never strike an arc on a cylinder.
5. For additional information, refer to CGA Standard P-1, "Precautions for Safe Handling of Compressed Gases in Cylinders", which is available from the Compressed Gas Association, 1235 Jefferson Davis Highway, Arlington, VA 22202.

ADDITIONAL SAFETY INFORMATION - For more information on safe practices for oxy-fuel welding and cutting equipment, ask your distributor for a copy of "Precautions and Safe Practices for Gas Welding, Cutting, and Heating", Form 2035. Gas apparatus safety guidelines are also available on video cassettes from your distributor.



The following publications, which are available from the American Welding Society, 550 N.W. LeJuene Road, Miami, FL 33126, are recommended to you:

1. ANSI/AWS Z49.1 - "Safety in Welding and Cutting".
2. AWS F4.1 - "Recommended Safe Practices for the Preparation for Welding and Cutting of Containers and Piping That Have Held Hazardous Substances".
3. AWS SP - "Safe Practices" - Reprint, Welding Handbook.



This symbol appearing in this manual means **Attention! Be Alert! Your safety is involved.**



Used to call attention to immediate hazards which, if not avoided, will result in immediate, serious personal injury or loss of life.



Used to call attention to potential hazards which could result in personal injury or loss of life.



Used to call attention to hazards which could result in minor personal injury.

**PUROX® CW-300
Cutting Attachment**

Cutting Range using acetylene 1/16 to 8 in.
 Cutting Range using
 other fuel gases 1/16 to 4 in.
 Cutting Nozzles (CW-300)..... 4200 series

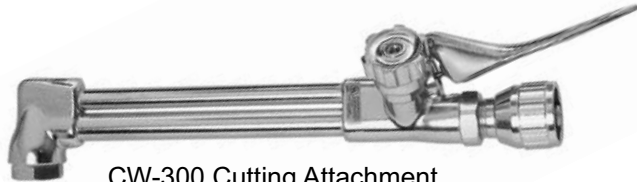

CW-300 Cutting Attachment
 (90 deg. Head) - P/N 999340
 (75 deg. Head) - P/N 999341
 (180 deg. Head) - P/N 18544

- Ease-on control of cutting oxygen for smoother starts
- Adapts torch to oxy-fuel cutting
- Unique piston-type “O” ring seals provide positive, leak-proof connections
- Also effective for pad washing, gouging and rivet washing
- Operates with all medium pressure acetylene and other fuel gases
- Valve packing nut contained under handwheel to resist stem damage

PUROX® W-300 Torch

Welding Range Thin gauge to over 1 in.
 Heating Range 1 to 200 cfh acetylene

Equivalent to approximately 1400 to 300,000 Btu/hr.
 Acetylene and other fuel gases may be used.



W-300 Welding Torch
 P/N 999339

- Ideal for all welding, brazing or medium heating applications in average production, repair or maintenance work
- Recommended for manual operations requiring speed and uninterrupted welding, heating and brazing
- Operates on medium pressure acetylene and other fuel gases
- Gas-mixer – high resistance to backfires, flame pops and flashbacks
- Roll stamped permanent identification
- Extra length Teflon valve packing for improved backlash characteristics



W-300 Standard Acetylene Single
 Flame Welding Heads



W-300 Standard Multiflame Heating
 Heads



W-300 Rosebud Style Multiflame
 Heating Heads

**OXWELD® CW-400
Cutting Attachment**

Cutting Range using acetylene 1/16 to 8 in.
 Cutting Range using
 other fuel gases 1/16 to 4 in.
 Cutting Nozzles (CW-400) 1500 series



CW-400 Cutting Attachment
 (90 deg. Head) - P/N 999046
 (75 deg. Head) - P/N 999622

- Ease-on control of cutting oxygen for smoother starts
- Adapts torch to oxy-fuel cutting
- Unique piston-type "O" ring seals provide positive, leak-proof connections
- Also effective for pad washing, gouging and rivet washing
- Operates with all medium pressure acetylene and other fuel gases
- Valve packing nut contained under handwheel to resist stem damage

OXWELD® W-400 Torch

Welding Range Thin gauge to over 1 in.
 Heating Range 1 to 200 cfh acetylene

Equivalent to approximately 1400 to 300,000 Btu/hr.
 Acetylene and other fuel gases may be used.



W-400 Welding Torch
 P/N 999045

- Ideal for all welding, brazing or medium heating applications in average production, repair or maintenance work
- Recommended for manual operations requiring speed and uninterrupted welding, heating and brazing
- Operates on medium pressure acetylene and other fuel gases
- Gas-mixer – high resistance to backfires, flame pops and flashbacks
- Roll stamped permanent identification
- Extra length Teflon valve packing for improved backlash characteristics



**W-400 Standard Acetylene Single
Flame Welding Heads**



**W-400 Standard Multiflame Heating
Heads**



**W-400 Rosebud Style Multiflame
Heating Heads**

Welding and Heating Head Extensions for W-300, -400, -500, -17
 Permit working at a comfortable distance from heat during
 heavy welding and heating jobs.



OPERATING INSTRUCTIONS

CONNECTING

1. Attach regulators to the oxygen and fuel gas cylinders. Follow all instructions supplied with your regulators.
2. Attach oxygen and fuel gas hoses (see Note 1 in Operating Data section on page 4 for recommended hose sizes) to the regulators and to the torch handle, after making sure all metal seating surfaces are clean. Tighten all connection nuts with a wrench.
3. Using Welding or Heating Head: Remove welding head connection nut from torch handle. Insert welding head into handle using slight back and forth twisting motion as you push. Slip connection nut over the head and hand-tighten to handle.

Using Cutting Attachment: Set the welding head connection nut aside and insert the cutting attachment to the torch handle in the same manner as the welding head. Remove nozzle nut and insert cutting nozzle into the cutting attachment head. Slip nut over the nozzle and tighten with a wrench.

4. Check throttle valve packing nuts for tightness.

**Flashbacks can cause serious burns.**

Be sure gas flow is sufficient for head or nozzle size. Adjust regulators for proper psig pressures. Adjust throttle valves properly. Keep torch in good repair. **DO NOT** throttle back gases to use large head or nozzle on thin material.

ADJUSTING GAS PRESSURES

Fuel Gas: With oxygen valve closed, open the fuel gas valve on the torch handle about one turn. Turn in the pressure-adjusting screw on the fuel gas regulator until its delivery-pressure gauge indicates the desired pressure (refer to operating tables starting on page 5). Then immediately close the torch fuel gas valve.

Oxygen, Using Welding or Heating Head: Open the torch oxygen valve at least 1-1/2 turns. Adjust oxygen pressure at the regulator to the desired pressure (refer to Table 2, 3 or 4) and then close the torch oxygen valve.

Oxygen, Using Cutting Attachment: Open the torch oxygen valve WIDE and leave the preheat oxygen valve on the cutting attachment closed. Depress the cutting oxygen valve lever on the cutting attachment. Adjust the oxygen pressure at the regulator to the desired pressure (refer to table 5, 6, 7 or 8). Shut off the oxygen flow by releasing the cutting oxygen valve lever only.

TESTING FOR LEAKS

Every welding and cutting outfit should be thoroughly tested for leaks after it is first hooked up, and at regular intervals thereafter. After all connections have been made, make sure both valves on the torch handle are closed. Then turn in the regulator pressure-adjusting screws clockwise until the oxygen delivery-pressure gauge registers 50 psi, the fuel gas delivery-pressure gauge registers 10 psi. Using Leak Test Solution suitable for oxygen service, such as P/N 998771 (8oz. container), check for leaks at the cylinder valves, the cylinder-to-regulator connections, the regulator-to-hose connections, and the hose-to-torch connections. If bubbling at any point indicates leakage, tighten the connection. If this does not stop the leakage, close the appropriate cylinder valve, open the torch valve to remove all pressure from the line, and finally release the regulator pressure-adjusting screw by turning it counterclockwise. Then break the leaky connections, wipe metal seating surfaces with a clean, dry cloth, and examine them for nicks and scratches. Remake the connection(s) and retest. Do not try to light the torch until you are satisfied that all connections are gas-tight.

LIGHTING & FLAME ADJUSTMENT

CAUTION: Use friction lighter for lighting torch. Do NOT use a match. Use of a match can seriously burn your hand.

Welding or Heating Head (Acetylene)

1. Open fuel gas valve about 1/2 turn and light the gas at the tip.
2. Slowly close the fuel gas valve until the yellow flame just starts to throw off smoke.
3. Open oxygen valve slowly until you have a neutral flame.
4. If harsher or soft flame is desired, readjust the two valves.

NOTE: When operating with a very soft flame, the welding head will tend to heat up and transfer some of this heat back to the torch handle. This may create some discomfort to the operator.

Heating Head (Fuel Gases except Acetylene)

1. Crack fuel gas valve and light the gas at the tip.
2. Open fuel gas valve until flames start to leave end of tip.
3. Slowly open oxygen valve until flames are at their shortest lengths.
4. If necessary, alternately open fuel gas and oxygen valves to the desired flame size.

Cutting Attachment (Acetylene)

1. Open the acetylene valve on the torch handle about 1/2 turn, and light the gas at the nozzle.
2. Slowly close the acetylene throttle valve until the yellow flame just starts to throw off black smoke.
3. Slowly open preheat oxygen valve on cutting attachment until neutral flames are obtained.
4. Finally, open the cutting oxygen valve by depressing lever and readjust the neutral flames by turning preheat oxygen valve.

The flame now has the proper strength for any cutting job. With this flame, acetylene is being consumed economically and the cutting attachment will be operating at best resistance to flashback. If greater preheat flame temperature is desired for faster starts or piercing, open the cutting oxygen valve and adjust the preheat oxygen valve until the flame inner cores shorten about 10 percent and become sharply pointed.

Cutting Attachment (Fuel Gases except Acetylene)

1. Crack the fuel gas valve and light the gas at the nozzle.
2. Open the fuel gas valve until flame starts to leave the end of the nozzle.
3. Slowly open preheat oxygen valve on cutting attachment until flame stabilizes.
4. Depress lever to open cutting oxygen valve and then adjust preheat oxygen valve until preheat flames are at their shortest length.
5. If larger or smaller preheat flames are desired, depress cutting oxygen valve lever and alternately readjust fuel gas and preheat oxygen valve to obtain the final flame setting.

SHUTTING OFF

Close the fuel gas valve first, then the oxygen valve whether you are using a welding head or cutting attachment. However, if the cutting attachment is to be relighted within a half-hour, you may close the preheat oxygen valve on the attachment instead of the oxygen valve on the torch handle.

If operations are to be stopped for a half-hour or more, you should release all pressure from regulators. To do this, first close both cylinder valves. Then open the torch valves. Finally, back out the regulator pressure-adjusting screws until they turn freely.

OPERATING PRECAUTIONS

Do not exceed 15 psig acetylene during operation.

Flow: There must be proper flow of gases for safe operation and full performance. This requires the following three conditions: (1) the regulators that determine the inlet pressure to the hoses must be set to the correct pressure; (2) the hoses and their connectors must have adequate capacity for the job (hoses that are too long, too small or have connectors with small passageways can cause problems); and (3) the throttle valves on the torch must be adjusted with the procedure shown in these instructions.

Note: Items (1) and (2) can be checked by measuring the gas pressures at the torch. Gauge adaptors are available for this purpose.

Backfire: Improper operation of the torch or cutting attachment may cause the flame to go out with a loud 'pop'. (If you are welding, the flame will often reignite instantly.) Such a backfire may be caused by contact of tip or nozzle with the work, by spatter from the work, by the use of incorrect gas pressure, or by leakage at the cutting nozzle seats due to dirt or nicks on seats or to a loose nozzle nut. After a backfire, you can normally relight the flames immediately. However, if backfires occur repeatedly, shut off the torch. Check the 'O'-ring seals between the welding head or cutting attachment and the handle, and the nozzle seats (if cutting). Readjust operating pressure and relight.

Flashback: Under certain circumstances, the flame may not 'pop' out (backfire) but instead burn back inside the torch with a shrill hissing or squeal. This is called a 'flashback'. A flashback should never occur if (1) the equipment is in good condition; (2) preheat ports on cutting nozzles or welding tips are cleaned frequently; (3) operating pressures are correct; and (4) throttle valves are adjusted properly. Should a flashback occur, IMMEDIATELY shut off the torch. Allow it to cool off for at least a minute. Then check your nozzle or tip, gas pressures, readjust regulators if necessary, and relight the torch. If flashback recurs, send the torch handle and welding head or cutting attachment to your distributor for repair.

IMPORTANT OPERATING NOTES

- Pressures given in Tables 2 through 8 are measured at the regulator using 25-ft. long hoses (1/4-in. I.D. up through size No. 30 welding/heating head or for cutting up to 3-in. thick steel; 3/8-in. I.D. for larger heads or cutting nozzles). If longer hoses are required, only 3/8-in. I.D. hoses should be used and pressure drop between regulator and torch should be considered. Use test gauge adaptors to check for proper pressure at torch if using long hose lengths, or if there are doubts about the adequacy of gas flows. Do NOT use hose line check valves when operating No. 55 and larger heads.
- Head size number on each welding and heating head indicates the rated acetylene flow capacity in cubic feet/hour (cfh). For example, No. 55A requires about 55 cfh of acetylene at the given operating pressures. However, on heating heads designed for other fuel gases, the size indicates the approximate equivalent heating capacity in terms of acetylene flow. For example, note from Table 3 that No. 100A and No. 100FG provide the same average heating output (147,000 Bt/hr) but No. 100FG head really requires about 62 cfh of FG-2, 57 cfh of propane, or 147 cfh of natural gas.

For consumption purposes, the following are the oxygen fuel gas ratios normally required for welding and heating:

- 1.1 to 1.5 cfh oxygen/1.0 cfh acetylene
- 3.2 to 3.6 cfh oxygen/1.0 cfh FG-2
- 3.5 to 4.5 cfh oxygen/1.0 cfh propane
- 1.7 to 2.0 cfh oxygen/1.0 cfh natural gas

- Correct pressure and flow must be maintained for proper operation of a welding or heating head. If a tip is "starved" due to insufficient flow of fuel gas, the tip may overheat and cause backfire or flashback.

An acetylene or a liquefied fuel gas (LFG) cylinder has a limited capacity for delivering fuel to the tip; therefore, it is extremely important to manifold 2 or more cylinder when operating larger heads to assure adequate supply of fuel gas to the tip. The rate of withdrawal depends on type of fuel gas cylinder size, the contents remaining, and the outside temperature. Tabulated below is the number of the more commonly used cylinders recommended for manifolding when using larger heads. If using other cylinders or gases, check with your fuel gas supplier for recommended withdrawal rate information.

- The tables show average values based on typical conditions. The type and quality of steel, its surface condition, and purity of oxygen, etc., will always have a bearing on the end results.

Head Size	Flowrate, cfh	Min. No. of Cylinders Required*	
		WK Cyl (300 cf)	WLT Cyl. (390 cf)
55	55	2	1
70	70	2	2
100	100	3	2
150	150	4	3
200	200	5	4
250	250	6	5
300	300	7	6

* Based on that max. hourly flowrate should not exceed 1/7 of cylinder capacity at 70° F.
Example 1/7 (300 of WK cyl.) = 43 cfh max.

Head Size	FG-2 (104 lb. cyl.)		Propane (100 lb. of cyl.)	
	Flowrate, cfh	Min. No. of Cyl. Req'd*	Flowrate, cfh	Min. No. of Cyl. Req'd**
70	43	1	40	1
100	62	1	58	1
150	93	1	86	2
200	124	2	116	2
300	186	2	174	3
500	310	3	290	5

*Based on max. continuous withdrawal rate of 110 cfh for 104 lb. cylinder, 1/2 full @ 70o F.

**Based on max. continuous withdrawal rate of 65 cfh for 100 lb. cylinder, 1/2 full @ 70o F.

Withdrawal rate will increase with wind velocity and intermittent usage; reduce with lower temperature.

Table 2 - W-300 & W-400 Acetylene Welding Heads (Single-Flame)

Complete Head Assembly		Steel Thickness, in.	Pressure, psig		Replacement Parts (See Fig.2)			Accessory	Tip Cleaning	
Size ◇	Part No.		Oxy.	Acet.	Tip	Mixer Throat	Mixer	Tip Extension	Drill Size	
1A	639438	to 32 ga.	5-8	5-8	639682	—	639885	—	78	
2A	639439	32 - 25 ga.			639683	—	639885	—	—	72
4A	639440	25 ga. - 1/32			639684	—	639886	—	—	64
6A	639441	1/32 - 1/16			639685	—	639887	—	—	62
9A	639442	1/16 - 1/8			639686	17513	19484	—	—	55
12A	17268	1/8 - 3/16			17266	17513	17514	—	—	54
15A	639443	3/16 - 1/4			639687	639693	639436	—	—	53
30A	17263	1/4 - 3/8			17261	17262	639437	—	—	45
55A	998085	3/8 - 5/8	7-9	7-9	998060	21K77	639965	19X42(12")	33	
70A	998086	5/8 - 1			998061	21K78	639966	19X42(12")	30	
100A	998087	over 1			998062	639993	639992	19X43(15")	25	

◇ Size indicates approx. acetylene flow rate in cu. ft./hr. (cfh) at normal operating pressure. See Important Operating Notes on page 4.

Table 3 - W-300 & W-400 Multiflame Heating Heads

Complete Head Assembly		Pressure, psig		No. of Flames	Avg. Heat Output Btu/hr.	Replacement Parts (See Fig. 2)			Accessory	Tip Cleaning
Size ◇	Part No.	Oxy.	Fuel Gas			Tip	Mixer Throat	Mixer	Tip Extension	Drill Size
For Oxy-Acetylene Use										
55A	998089	7-9	7-9	7	81,000	998070	21K77	639965	19X42 (12")	59
70A	998090	7-9	7-9	7	102,000	998071	21K78	639966	19X42 (12")	56
100A	998091	10-12	10-12	8	147,000	998072	639993	639992	19X43 (15")	55
150A	998092	12-14	12-14	12	221,000	998073	639994	639992	19X44 (18")	55
For Oxy-Fuel Gas Use - FG-2, propane, natural gas, etc.										
70FG	998093	16-20	7-10	7	104,000	998078	21K78	639966	19X42 (12")	54
100FG	998278	35-39	7-10	8	147,000	998079	998035	998034	19X43 (15")	48
150FG	998276	30-35	7-10	12	220,000	998036	639994	639992	19X44 (18")	48

◇ See Important Operating Notes on page 4.

Table 4 - W300 & W-400 Rosebud Style Multiflame Heating Heads

Complete Head Assembly		Pressure, psig		No. of Flames	Avg. Heat Output Btu/hr.	Replacement Parts (See Fig. 2)					Accessory		Tip Cleaning
Size ◇	Part No.	Oxy.	Fuel Gas			Tip Assy.	Stem	Mixer Throat	Mixer	Conn. Nut	Retain. Ring	Tip Extension Length	P/N
For Oxy-Acetylene Use													
15 O-A	998773	5-8	5-8	6	22,000	998795	998791	639693	639436	998580	13K02	—	70
30 O-A	998774	5-8	5-8	6	44,000	998796	998791	639694	639437	998580	13K02	—	62
55 O-A	998775	7-9	7-9	9	81,000	998797	998792	21K77	639965	998580	13K02	12-in.	19X42
70 O-A	998776	7-9	7-9	9	103,000	998798	998792	21K78	639966	998580	13K02	12-in.	19X42
100 O-A	998777	13-16	8-10	13	147,000	998799	998793	639993	639992	639995	639709	15-in.	19X43
200 O-A	998778	19-22	11-14	16	294,000	998800	998794	998779	998780	639995	639970	18-in.	998790♦
For Oxy-Fuel Gas Use - FG-2, propane, natural gas, etc.													
70 O-FG	999225	13-24	6-13	8	104,000	999224	998792	21K78	639966	998580	13K02	12-in.	19X42
100 O-FG	999228	18-31	8-15	8	148,000	999227	998793	998035	998034	639995	639970	15-in.	19X43
200 O-FG	999231	38-60	9-17	24	297,000	999230	998794	998045	22K39	639995	639970	18-in.	998790♦

◇ See Important Operating Notes on pg. 4.

♦ Requires extension coupling 998838.

Table 5 - 4202 Series Acetylene Cutting Nozzles (CW-300)

Nozzle		Steel Thickness, in.	Pressure, psig		Gas Consumption, ft ³ /hr		Cleaning Drill Size	
Size	Part No.		Oxygen	Acetylene	Oxygen	Acetylene	Preheat	Cutting
1/8"	638869	1/8	30-40	5	31-34	8-9	73	76
1/4"	16K08	1/4	25-30	5	42-45	8-10	73	68
1/2"	16K09	1/2	30-40	5	70-75	10-12	73	60
1-1/2"	16K10	3/4	25-30	5	95-100	12-14	69	52
		1	35-40	6	120-125	14-16		
		1-1/2	50-55	7	165-170	16-18		
4"	16K11	2	40-45	5	195-200	18-20	68	50
		3	45-60	6	230-235	20-22		
		4	50-55	6	315-320	23-25		
6"	16K12	6	60-70	8	460-470	30-32	64	43
10"	16K13	8	80-90	10	605-615	36-38	60	35

Table 6 - 4217 Series Fuel Gas Two-Piece Cutting Nozzles

NOTE: Do NOT use with Acetylene.

Nozzle Size	Nozzle (Internal) P/N	Sleeve (External) P/N	Steel Thickness, in.	Pressure, psig				Gas Consumption, ft ³ /hr				Cleaning Drill Size Cutting*
				Oxygen	Fuel Gas			Oxygen	Fuel Gas			
					FG-2	Propane	Nat. Gas		FG-2	Propane	Nat. Gas	
1/4"	19485	19518	1/4"	30	4	6	7	70	8	12	30	68
1/2"	19486	19518	1/2"	35	4	7	8	120	9	14	32	60
1"	19487	19518	1"	40	4	8	9	180	10	15	35	53
2"	19488	19518	2"	45	5	9	10	250	11	16	40	50
4"	19489	19519	4"	40	4	8	10	370	12	18	45	43

• Use soft-bristled bush (750F99) to clean preheat slots of internal nozzles.

Table 7 - 1565 & 1502 Series Acetylene Cutting Nozzles (CW-400)

Nozzle		Steel Thickness		Gas Pressure, psig		Gas Consumption, ft ³ /hr		Cleaning Drill Size				
Size	Part No.	in.	mm	Oxygen	Acetylene	Oxygen	Acetylene	Preheat	Cutting			
1564 Series (Low Acetylene Consumption)												
1/8"	639182	1/8	3	42	5-8	15-20	5-9	73	78			
1/4"	639263	1/4	6			35-40						
1/2"	639264	1/2	13			55-65						
3/4"	639265	3/4	19			60-70						
1"	639266	1	25			85-905						
2"	639267	2	50			155-165				8-12	70	51
3"	639268	3	75			215-230				10-15	69	47
4"	639269	4	100			340-360				15-20	65	40
6"	998742	6	150	35-45	8-10	395-460	20-25	57	39			
		8	200	55-65		545-625	30-35					
1502 Series (Medium Preheat)												
1/4"	08Z67	1/4	6	25-30	5-8	35-45	6-8	69	68			
1/2"	15Z17	1/2	13	35-40		65-75	8-10	66	60			
1-1/2"	15Z18	3/4	19	35-40		120-135	14-16	65	53			
		1	25	40-45	5-8	130-140	14-16					
4"	15Z19	2	50	30-35		185-210	16-20	61	46			
		3	75	40-45	6-9	205-255	16-20					
		4	100	45-50		235-285	19-22					
8"	15Z20	6	150	35-45		395-460	20-25	57	39			
		8	200	55-65	8-10	545-625	30-35					

Table 8 - 1567 & 1534 Series Fuel Gas Two-Piece Cutting Nozzles (CW-400) Note: Do NOT use with acetylene

Nozzle Size	Nozzle (Internal) Part No.	Sleeve (External)			Steel Thickness		Gas Pressure, psig		Gas Consumption, ft ³ /hr			Cleaning Drill Size Cutting●
		Nat. Gas Propane	FG-2 MAPP	FG-2 MAPP◆	in.	mm	Oxygen	Fuel Gas	Oxygen	FG-2■	Nat. Gas	
1567 Series (High Preheat)												
1/8	639614	639322	998277	998557	1/8	3	40	3-4	20-40	5-10	20-25	79
1/4	639615				1/4	6			45-65	5-10	20-25	69
1/2	639616				1/2	13			65-85	5-10	20-25	65
3/4	639617				3/4	19			70-90	5-10	20-25	61
1	639618				1	25			95-115	5-10	25-30	54
2	639619				2	50			175-200	8-15	30-35	51
3	639620	3	75	235-260	8-15	35-40	47					
4	998734	14Z39	114Z08	998561	4	100	40	4-5	285-305	8-15	35-40	46
1534 Series (Medium Preheat)												
2	14Z66	14Z38	114Z07	998560	1/8	3	30	3-4	25-45	5-10	15-20	76
3	14Z50				1/4	6			45-65			
4	14Z51				1/2	13			70-90			
6	14Z52	14Z39	114Z08	998561	3/4	19	30	3-4	125-145	5-10	15-20	53
8	14Z53	14Z39	114Z08	998561	1	25	40	4-5	140-160	8-15	30-40	46
					2	50			150-170			
					3	75			280-300			
					4	100	40		285-305			

- ◆ Use where high preheat intensity is desired.
- Consumption of MAPP or propane is approximately the same as FG-2.
- Use soft-bristled brush (750F99) to clean preheat slots of internal nozzles.

MAINTENANCE INSTRUCTIONS

For all repairs other than those covered below, send the apparatus to your welding equipment distributor or to ESAB Remanufacturing Center, 411 S. Ebenezer Road, Florence, SC 29501. Improperly repaired apparatus is hazardous.

Torch Handle and Cutting Attachment Throttle Valves -
Leakage around throttle valve can almost always be corrected by tightening the packing nut slightly. If necessary, replace the complete throttle valve assembly as directed below. If a valve will not shut off completely loosen the packing nut and unscrew the throttle valve assembly from the body. Wipe the stainless steel ball seat on the valve stem, and the seating surface in the body, with a clean cloth. Then reinstall the valve, retighten the packing nut, and operate the valve several times, closing it with maximum force. If this does not end the leakage, install a new throttle valve assembly. When you do so, tighten the packing nut

Cutting Valve — If leakage is detected around the cutting valve, or if the valve does not shut off completely when cutting oxygen valve lever is released, unscrew the lock screw (see illustration on pg. 8) with a spanner wrench. When the thread is fully disengaged, lift out the valve assembly. Then tilt the attachment and let the valve spring drop out in you hand.

Now pull the lock screw off the valve stem and remove seat and retainer from the stem. Examine the stem carefully. If either the seating surface or the cylindrical section that runs in the valve screw is marred, replace the stem with a new part. Always replace the seat with a new part. Replace the small 'O'-ring and replace it if it is not in excellent condition. Place new seat on stem, slide on the retainer, and insert stem in lock screw (be sure the lock screw has both 'O'-rings in position). Finally, slide valve spring into body, insert valve assembly, and tighten lock screw.

Cutting Attachment Mixer — To remove the mixer for cleaning or replacement, back off locknut (56K07) until it reaches the end of the threads on the adaptor (19K07). Continue turning it, with a wrench, to unscrew the adaptor from the attachment body. Then remove the mixer by grasping the end of the mixer carefully with a pair of pliers and pull it out. Clean mixer center orifice with a No. 55 cleaning drill and the cross-drillings with a No. 66 drill, or soak the mixer overnight in a solution of OXWELD Nozzle Cleaning Compound (P/N 761F00), rinse, and blow dry with clean air.

Inspect all 'O'rings and replace them if they are not in good condition. Reassemble in reverse order, and tighten locknut against body securely.

Welding Heads and Cutting Nozzles — Welding heads and cutting nozzle orifices should be cleaned by hand using OXWELD tip cleaners, whenever a flame distortion is noted. Maintaining clean orifices is highly recommended for reducing any incidence of flashbacks. If you do not have tip cleaners, twist drills of the correct sizes (see Tables) may be used. Insert the drill carefully, and push it back and forth. **DO NOT TWIST THE DRILL.**

If a welding tip requires replacement, secure the front end of the mixer throat in a vise and unscrew the tip. Before installing a new tip, be sure it matches the mixer throat in size (both parts are size-stamped). Always tighten the new tip as much as you can without bending it.

To clean a welding head mixer, unscrew it from the mixer throat, soak it overnight in a solution of OXWELD Nozzle Cleaning Compound, rinse with clear water, dry with a jet of air.

Check the condition of 'O'-rings on the welding heads periodically. If they appear to be in poor condition, or are so worn that the head can be inserted in the handle without noticeable resistance, replace them.

GENERAL

Replacement Parts are illustrated on the following figures. When ordering replacement parts, order by part number and part name, as illustrated on the figure.

ORDERING

To assure proper operation, it is recommended that only genuine ESAB parts and products be used with this equipment. The use of non-ESAB parts may void your warranty.

Replacement parts may be ordered from your ESAB distributor or from:

ESAB Welding & Cutting Products
Attn: Customer Service Dept.
P.O. Box 100545, 411 S. Ebenezer Road
Florence, SC 29501-0545

Be sure to indicate any special shipping instructions when ordering replacement parts.

To order parts by phone, contact ESAB at 1-843-664-5540. Orders may also be faxed to 1-800-634-7548. Be sure to indicate any special shipping instructions when ordering replacement parts.

Refer to the Communication Guide located on the last page of this manual for a list of customer service phone numbers.

PARTS INFORMATION

All parts which can be replaced without breaking soldered or brazed joints are illustrated below. When ordering parts, please give both part number and description (including size, where appropriate). Parts may be ordered from your welding equipment distributor or from The ESAB Welding & Cutting Products, Customer Service Department, Florence, SC.

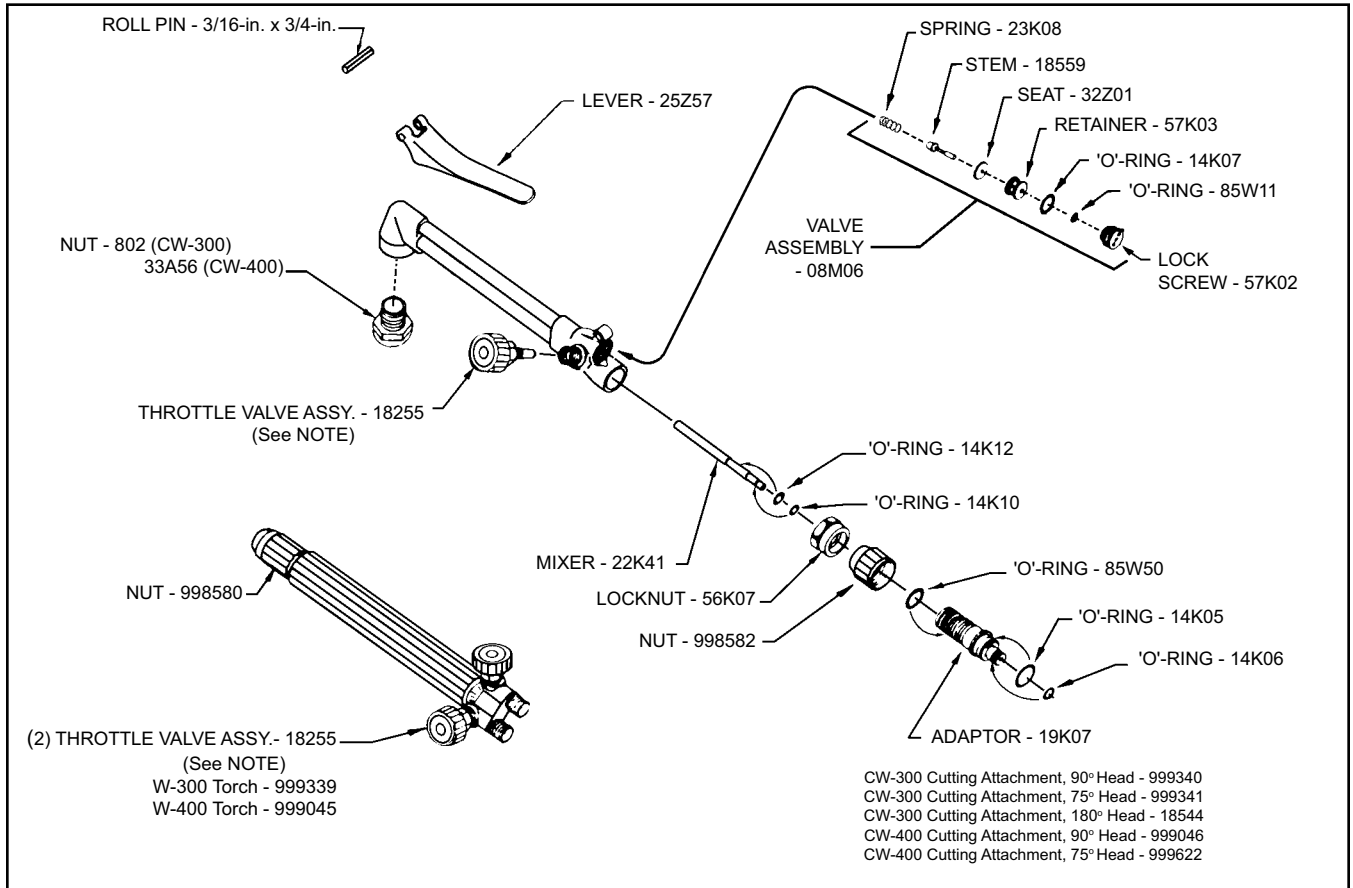

Fig. 1 - Replacement Parts - Welding Torch and Cutting Attachment Assemblies

NOTE: Valve Stem P/N 18255 with 5/16" — 32 threaded stem replaced P/N 999019, which had 5/16" — 24 threaded stem, for improved flow control in the 4th quarter, 1987. The two stems are not interchangeable. P/N 18255 is identified by having "32" stamped on the handwheel.

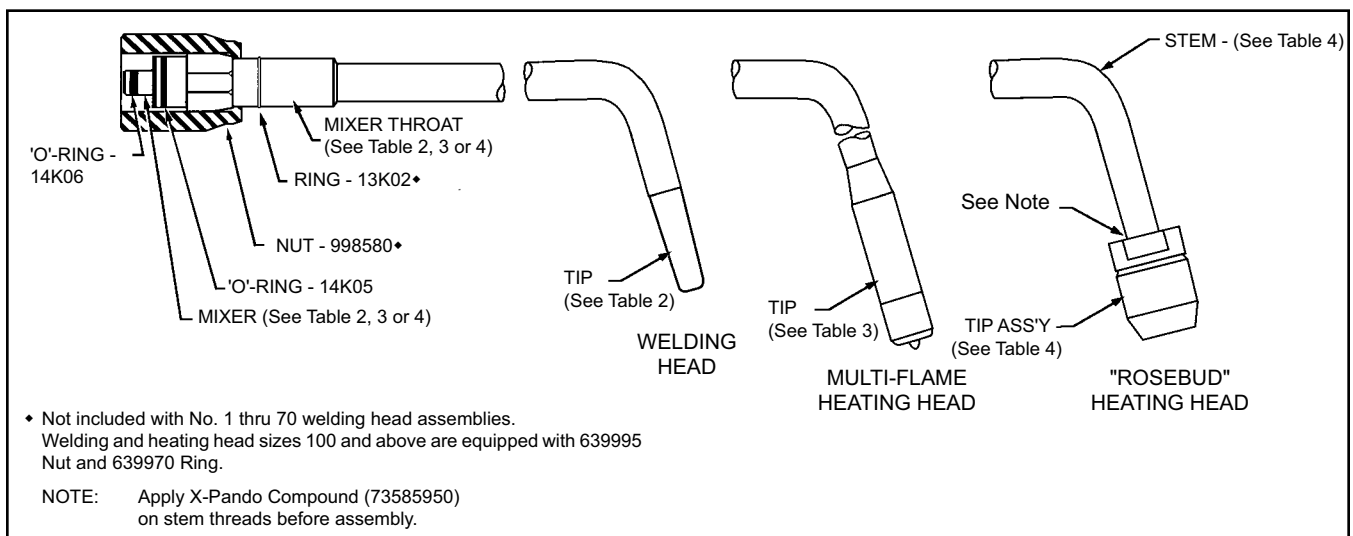

Fig. 2 Replacement Parts - Welding and Heating Head Assemblies

PUROX® and OXWELD® are registered trademarks of ESAB Welding & Cutting Products

REVISION HISTORY

1. Revision "G" removed pin and spring per CN# 043094. Updated format also.

ESAB Welding & Cutting Products, Florence, SC Welding Equipment
COMMUNICATION GUIDE - CUSTOMER SERVICES

A. CUSTOMER SERVICE QUESTIONS:

Order Entry	Product Availability	Pricing	Delivery
Order Changes	Saleable Goods Returns	Shipping Information	

Eastern Distribution Center
Telephone: (800)362-7080 / Fax: (800) 634-7548

Central Distribution Center
Telephone: (800)783-5360 / Fax: (800) 783-5362

Western Distribution Center
Telephone: (800) 235-4012/ Fax: (888) 586-4670

B. ENGINEERING SERVICE: Telephone: (843) 664-4416 / Fax : (800) 446-5693

Welding Equipment Troubleshooting	Hours: 7:30 AM to 5:00 PM EST
Warranty Returns	Authorized Repair Stations

C. TECHNICAL SERVICE: Telephone: (800) ESAB-123/ Fax: (843) 664-4452

Part Numbers	Technical Applications	Hours: 8:00 AM to 5:00 PM EST
Performance Features	Technical Specifications	Equipment Recommendations

D. LITERATURE REQUESTS: Telephone: (843) 664-5562 / Fax: (843) 664-5548

Hours: 7:30 AM to 4:00 PM EST

E. WELDING EQUIPMENT REPAIRS: Telephone: (843) 664-4487 / Fax: (843) 664-5557

Repair Estimates	Repair Status	Hours: 7:30 AM to 3:30 PM EST
------------------	---------------	-------------------------------

F. WELDING EQUIPMENT TRAINING:

Telephone: (843)664-4428 / Fax: (843) 679-5864	
Training School Information and Registrations	Hours: 7:30 AM to 4:00 PM EST

G. WELDING PROCESS ASSISTANCE:

Telephone: (800) ESAB-123 / Fax: (843) 664-4454	Hours: 7:30 AM to 4:00 PM EST
---	-------------------------------

H. TECHNICAL ASST. CONSUMABLES:

Telephone : (800) 933-7070	Hours: 7:30 AM to 5:00 PM EST
----------------------------	-------------------------------

IF YOU DO NOT KNOW WHOM TO CALL

Telephone: (800) ESAB-123/ Fax: (843) 664-4452/ Web:<http://www.esab.com>

Hours: 7:30 AM to 5:00 PM EST

